



Urba 20, 23 and 25 litre bins can be produced in 75% post-consumer recycled plastic certified "Plastica Seconda Vita" (Second-Life plastic) from the Italian Institute for the Promotion of Recycled Plastics. This option supports the objectives for Green Procurement with the re-use of recycled plastic materials, to help minimise the impact on the environment in manufacture.



Sartori Ambiente is certified according to ISO 9001 and ISO 14001.



Items are packed using PEFC certified pallets.

Printed by - June 2010



URBA 20 · URBA 23 · URBA 25

Easy, practical and secure containers for the separate collection of food waste

Peter Ridley

Waste Systems

The Technology Centre, Station Road, Framlingham, Woodbridge, Suffolk IP13 9EZ.
tel: +44(0) 1728 726636, fax: +44(0) 1728 726637, email: office@peterridley.co.uk, website: www.peterridley.co.uk



SARTORI AMBIENTE
SUSTAINABLE ENVIRONMENTAL SOLUTIONS

Peter Ridley

Waste Systems

URBA 20/23/25

Urba 20, 23 and 25 containers ergonomically designed with tapered shaped body and square base with minimal footprint. They can be used in all types of properties, either inside or outside the home or office.



Sturdy hinges and clip-on lid



Robust handle with lid locking mechanism



Recessed hand grip on the base



Lid or body with IML printing option



Smooth internal surface (rounded inside corners for Urba 23)



TECHNICAL FEATURES

Capacity

- . 21, 23 or 26.5 litre

Material

- . 100% virgin recyclable PP, with options for recycled content.
- . Stabilised against the effects of UV light and the weather; resistant to chemical detergents and biological matter.

Lid

- . Wide front lip for finger-tip lid opening
- . Close fitting hinged lid to avoid unpleasant odour
- . Clip-on lid for quick easy assembly or replacement
- . Sloping lid to allow water run-off

Body

- . Upright style with tapered body
- . Sturdy lowered hinges for fitting a compostable liner
- . Radius corners to suspend the biobag
- . Wide flat area for body printing
- . Stackable or wall mountable
- . Smooth internal surface for easy cleaning
- . Rounded interior edges at the base to prevent residue build-up (Urba 23)
- . Recessed hand grip on the base to make emptying easier when the bin is inverted
- . Strengthened double rim with ribs for improved base wear (Urba 23)
- . Microchip nest

Handle

- . Vertical single piece black plastic handle with two pivot points
- . Secure grip for working with gloves
- . Allows the lid to be propped open
- . Lid locking mechanism to prevent spillage and interference from birds and animals
- . Vertical handle with lid locking mechanism
- . Two lid opening positions, two lid locking positions
- . Fast unlocking by moving the handle 70° from the locking position

Options

- . 30, 50 and 70% post-industrial recycled PP content
- . Certified 75% post-consumer recycled PP content
- . Thermal transfer printing in white on body front
- . Lid imprinting
- . Lid or body IML printing up to 4 colours to A4 size
- . Microchip insertion
- . High visibility clip-on reflectors or chevron style vinyl labels
- . Translucent lids
- . Wide range of other colours available on request

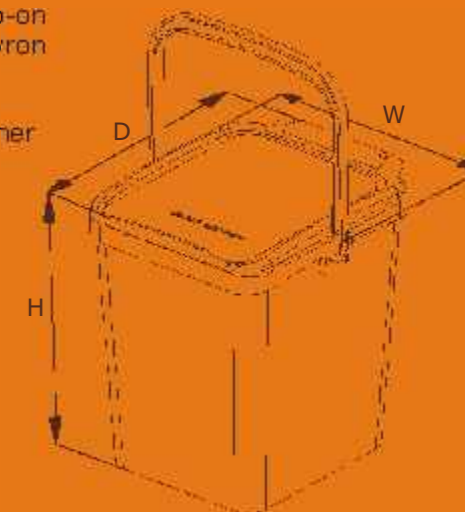

	Width W (mm)	Depth D (mm)	Height H (mm)	Volume (L)	Standard colours
Urba 20	295*	340	353	ca. 21	
Urba 23	295*	340	395	ca. 23	
Urba 25	295*	340	450	ca. 26,5	



* with handle | The manufacturer reserves the right to apply technical and aesthetical changes without notice